

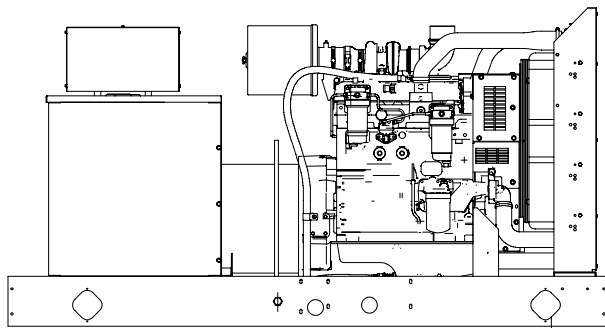

Ratings Range

60 Hz

Standby:	kW	80-100
	kVA	80-125
Prime:	kW	71-92
	kVA	71-115



Standard Features

- Kohler Co. provides one-source responsibility for the generating system and accessories.
- The generator set and its components are prototype-tested, factory-built, and production-tested.
- The 60 Hz generator set offers a UL 2200 listing.
- The generator set accepts rated load in one step.
- The 60 Hz generator set meets NFPA 110, Level 1, when equipped with the necessary accessories and installed per NFPA standards.
- The generator set complies with ISO 8528-5, Class G2, requirements for transient performance in all generator set configurations. Select the Decision-Maker™ 550 controller for improved voltage regulation and ISO 8528-5, Class G3, compliance.
- The 60 Hz generator set engine is certified by the Environmental Protection Agency (EPA) to conform to Tier 3 nonroad emissions regulations.
- A one-year limited warranty covers all systems and components. Two-, five-, and ten-year extended warranties are also available.
- Alternator features:
 - The unique Fast-Response™ II excitation system delivers excellent voltage response and short circuit capability using a permanent magnet (PM)-excited alternator.
 - The brushless, rotating-field alternator has broadrange reconnectability.
- Other features:
 - Controllers are available for all applications. See controller features inside.
 - The low coolant level shutdown prevents overheating (standard on radiator models only).
 - Integral vibration isolation eliminates the need for under-unit vibration spring isolators.

Generator Set Ratings

Alternator	Voltage	Ph	Hz	130° C Rise Standby Rating		105° C Rise Prime Rating	
				kW/kVA	Amps	kW/kVA	Amps
4S9W/4S9	120/208	3	60	100/125	347	90/113	312
	127/220	3	60	100/125	328	90/113	295
	120/240	3	60	100/125	301	90/113	271
	120/240	1	60	80/80	333	71/71	296
	139/240	3	60	100/125	301	91/114	274
	220/380	3	60	88/110	167	90/113	171
	277/480	3	60	100/125	150	91/114	137
	347/600	3	60	100/125	120	91/114	109
4S11W/4S11	120/208	3	60	100/125	347	91/114	316
	127/220	3	60	100/125	328	91/114	299
	120/240	3	60	100/125	301	91/114	274
	120/240	1	60	95/95	396	86/86	358
	139/240	3	60	100/125	301	92/115	277
	220/380	3	60	100/125	190	91/114	173
	277/480	3	60	100/125	150	92/115	138
4V11W/4V11	120/240	1	60	95/95	396	86/86	358

RATINGS: All three-phase units are rated at 0.8 power factor. All single-phase units are rated at 1.0 power factor. *Standby Ratings:* Standby ratings apply to installations served by a reliable utility source. The standby rating is applicable to varying loads for the duration of a power outage. There is no overload capability for this rating. Ratings are in accordance with ISO-3046/1, BS 5514, AS 2789, and DIN 6271. *Prime Power Ratings:* Prime power ratings apply to installations where utility power is unavailable or unreliable. At varying load, the number of generator set operating hours is unlimited. A 10% overload capacity is available for one hour in twelve. Ratings are in accordance with ISO-8528/1, overload power in accordance with ISO-3046/1, BS 5514, AS 2789, and DIN 6271. For limited running time and base load ratings, consult the factory. Obtain the technical information bulletin (TIB-101) on ratings guidelines for the complete ratings definitions. The generator set manufacturer reserves the right to change the design or specifications without notice and without any obligation or liability whatsoever. **GENERAL GUIDELINES FOR DERATION:** *Altitude:* Derate 1.3% per 100 m (328 ft.) elevation above 2500 m (8200 ft.). *Temperature:* Derate 1.0% per 10°C (18°F) temperature above 25°C (77°F).

Alternator Specifications

Specifications	Alternator
Manufacturer	Kohler
Type	4-Pole, Rotating-Field
Exciter type	Brushless, Permanent-Magnet
Leads: quantity, type	12, Reconnectable
Voltage regulator	Solid State, Volts/Hz
Insulation:	NEMA MG1
Material	Class H
Temperature rise	130°C, Standby
Bearing: quantity, type	1, Sealed
Coupling	Flexible Disc
Amortisseur windings	Full
Voltage regulation, no-load to full-load	
Permanent magnet (PM) alternator	±2% Average
550 controller (with 0.5% drift due to temperature variation)	3-Phase Sensing, ±0.25%
Unbalanced load capability	100% of Rated Standby Current
One-step load acceptance	100% of Rating
Peak motor starting kVA:	(35% dip for voltages below)
480 V 4S9W/4S9 (12 lead)	315
480 V 4S11W/4S11 (12 lead)	460
480 V 4V11W/4V11 (12 lead)	—

- NEMA MG1, IEEE, and ANSI standards compliance for temperature rise and motor starting.
- Sustained short-circuit current of up to 300% of the rated current for up to 10 seconds.
- Sustained short-circuit current enabling downstream circuit breakers to trip without collapsing the alternator field.
- Self-ventilated and dripproof construction.
- Vacuum-impregnated windings with fungus-resistant epoxy varnish for dependability and long life.
- Superior voltage waveform from a two-thirds pitch stator and skewed rotor.
- Fast-Response™ II brushless alternator with brushless exciter for excellent load response.

Application Data

Engine

Engine Specifications	
Manufacturer	John Deere
Engine model	4045HF285I
Engine type	4-Cycle, Turbocharged, Charge Air-Cooled
Cylinder arrangement	4 Inline
Displacement, L (cu. in.)	4.5 (276)
Bore and stroke, mm (in.)	106 x 127 (4.19 x 5.00)
Compression ratio	19:1
Piston speed, m/min. (ft./min.)	457 (1500)
Main bearings: quantity, type	5, Replaceable Insert
Rated rpm	1800
Max. power at rated rpm, kWm (BHP)	118 (158)
Cylinder head material	Cast Iron
Crankshaft material	Forged Steel
Valve material:	
Intake	Chromium-Silicon Steel
Exhaust	Stainless Steel
Governor: type, make/model	JDEC Electronic L16 Denso HP3
Frequency regulation, no-load to full-load	Isochronous
Frequency regulation, steady state	±0.25%
Frequency	Fixed
Air cleaner type, all models	Dry

Exhaust

Exhaust System	
Exhaust manifold type	Dry
Exhaust flow at rated kW, m ³ /min. (cfm)	22.8 (805)
Exhaust temperature at rated kW, dry exhaust, °C (°F)	580 (1076)
Maximum allowable back pressure, kPa (in. Hg)	7.5 (2.2)
Exhaust outlet size at engine hookup, mm (in.)	98 (3.86)

Engine Electrical

Engine Electrical System (12/24 Volt*)	
Battery charging alternator:	12 Volt/24 Volt
Ground (negative/positive)	Negative
Volts (DC)	12/24
Ampere rating	65/45
Starter motor rated voltage (DC)	12/24
Battery, recommended cold cranking amps (CCA):	12 Volt/24 Volt
Quantity, CCA rating each	One, 640/Two, 570
Battery voltage (DC)	12

*12-volt or 24-volt engine electrical systems are available.

Application Data

Fuel

Fuel System	
Fuel supply line, min. ID, mm (in.)	11.0 (0.44)
Fuel return line, min. ID, mm (in.)	6.0 (0.25)
Max. lift, fuel pump: type, m (ft.)	Engine-Driven, 1.8 (6.0)
Max. fuel flow, Lph (gph)	74.6 (19.7)
Fuel prime pump	Manual
Fuel filter	
Secondary	2 Microns @ 98% Efficiency
Primary	30 Microns
Water Separator	Yes
Recommended fuel	#2 Diesel

Lubrication

Lubricating System	
Type	Full Pressure
Oil pan capacity, L (qt.)	14.7 (15.5)
Oil pan capacity with filter, L (qt.)	15.6 (16.5)
Oil filter: quantity, type	1, Cartridge
Oil cooler	Water-Cooled

Cooling

Radiator System	
Ambient temperature, °C (°F)*	50 (122)
Engine jacket water capacity, L (gal.)	8.5 (2.25)
Radiator system capacity, including engine, L (gal.)	20.1 (5.3)
Engine jacket water flow, Lpm (gpm)	4182 (48)
Heat rejected to cooling water at rated kW, dry exhaust, kW (Btu/min.)	62 (3544)
Heat rejected to air charge cooler at rated kW, dry exhaust, kW (Btu/min.)	20 (1127)
Water pump type	Centrifugal
Fan diameter, including blades, mm (in.)	600 (23.6)
Fan, kWm (HP)	5.7 (7.6)
Max. restriction of cooling air, intake and discharge side of radiator, kPa (in. H ₂ O)	0.125 (0.5)
* Enclosure with enclosed silencer reduces ambient temperature capability by 5°C (9°F).	

Operation Requirements

Air Requirements	
Radiator-cooled cooling air, m ³ /min. (scfm)‡	161 (5700)
Combustion air, m ³ /min. (cfm)	8.2 (288)
Heat rejected to ambient air:	
Engine, kW (Btu/min.)	25.0 (1420)
Alternator, kW (Btu/min.)	11.6 (660)
‡ Air density = 1.20 kg/m ³ (0.075 lbm/ft ³)	

Fuel Consumption

Diesel, Lph (gph) at % load	Standby Rating
100%	31.0 (8.2)
75%	25.0 (6.6)
50%	17.8 (4.7)
25%	9.5 (2.5)
Diesel, Lph (gph) at % load	Prime Rating
100%	27.6 (7.3)
75%	22.7 (6.0)
50%	14.4 (3.8)
25%	7.6 (2.0)

Controllers

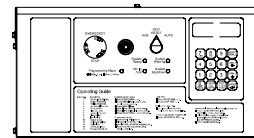

Decision-Maker™ 550 Controller

Audiovisual annunciation with NFPA 110 Level 1 capability. Programmable microprocessor logic and digital display features. Alternator safeguard circuit protection. 12- or 24-volt engine electrical system capability. Remote start, remote annunciation, and remote communication options. Refer to G6-46 for additional controller features and accessories.

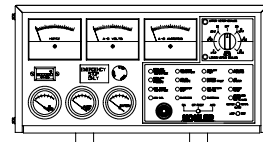

Decision-Maker™ 3+, 16-Light Controller

Audiovisual annunciation with NFPA 110 Level 1 capability. Microprocessor logic, AC meters, and engine gauge features. 12- or 24-volt engine electrical system capability. Remote start, prime power, and remote annunciation options. Refer to G6-30 for additional controller features and accessories.

Additional Standard Features

- Alternator Protection (standard with 550 controller)
- Battery Rack and Cables
- Emission Compliant Engine
- Integral Vibration Isolation
- Oil Drain Extension
- Operation and Installation Literature

Available Accessories

Enclosed Unit

- Sound Enclosure (with enclosed critical silencer)
- Weather Enclosure (with enclosed critical silencer)
- Weather Housing (with roof-mounted critical silencer)

Open Unit

- Exhaust Silencer, Critical (kit: PA-354809)
- Exhaust Silencer, Hospital (kit: PA-365349)
- Flexible Exhaust Connector, Stainless Steel

Cooling System

- Block Heater (recommended for ambient temperatures below 0°C [32°F])
- Radiator Duct Flange

Fuel System

- Auxiliary Fuel Pump
- Flexible Fuel Lines
- Fuel Pressure Gauge
- Subbase Fuel Tanks
- Subbase Fuel Tank with Day Tank

Electrical System

- Battery
- Battery Charger, Equalize/Float Type
- Battery Heater

Engine and Alternator

- Air Cleaner, Heavy Duty
- Air Cleaner Restriction Indicator
- Alternator Strip Heater
- Bus Bar Kits
- Closed Crankcase Canister
- CSA Certification
- Current Transformer Kit
- Line Circuit Breaker (NEMA type 1 enclosure)
- Line Circuit Breaker with Shunt Trip (NEMA type 1 enclosure)
- Optional Alternators
- Rated Power Factor Testing
- Rodent Guards
- Safeguard Breaker (not available with 550 controller)
- Skid End Caps
- Voltage Regulation, 1%
- Voltage Regulator Sensing, 3-Phase

Paralleling System

- Reactive Droop Compensator
- Voltage Adjust Control
- Voltage Regulator Relocation Kit

Maintenance

- General Maintenance Literature Kit
- Maintenance Kit (includes standard air, oil, and fuel filters)
- NFPA 110 Literature
- Overhaul Literature Kit
- Production Literature Kit

Controller

- Common Failure Relay Kit
- Communication Products and PC Software (550 controller only)
- Customer Connection Kit
- Dry Contact Kit (isolated alarm)
- Prime Power Switch (550 controller only)
- Remote Annunciator Panel
- Remote Audiovisual Alarm Panel
- Remote Emergency Stop Kit
- Remote Mounting Cable
- Run Relay Kit

Miscellaneous Accessories

- _____
- _____
- _____
- _____
- _____

Dimensions and Weights

Overall Size, L x W x H, mm (in.):

Wide Skid: 2400 x 1040 x 1274 (94.49 x 40.94 x 50.15)

Narrow Skid: 2400 x 864 x 1274 (94.49 x 34.02 x 50.15)

Weight (radiator model), wet, kg (lb.): 1234 (2720)

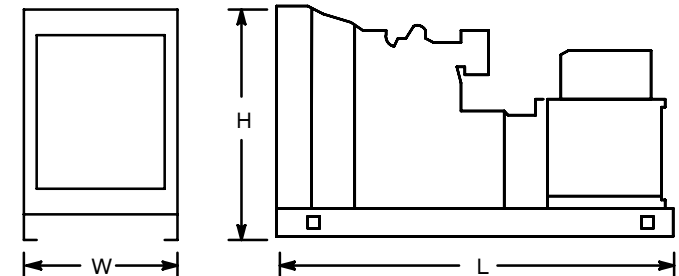

NOTE: This drawing is provided for reference only and should not be used for planning installation. Contact your local distributor for more detailed information.

DISTRIBUTED BY: