

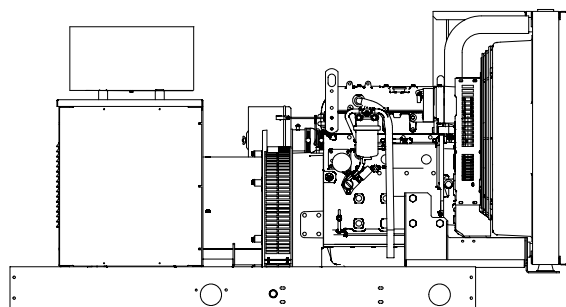

**Ratings Range**

|                 |            |              |
|-----------------|------------|--------------|
|                 |            | <b>60 Hz</b> |
| <b>Standby:</b> | <b>kW</b>  | 27-30        |
|                 | <b>kVA</b> | 27-38        |
| <b>Prime:</b>   | <b>kW</b>  | 24-26        |
|                 | <b>kVA</b> | 24-33        |



**Standard Features**

- Kohler Co. provides one-source responsibility for the generating system and accessories.
- The generator set and its components are prototype-tested, factory-built, and production-tested.
- The 60 Hz generator set offers a UL 2200 listing.
- The generator set accepts rated load in one step.
- The 60 Hz generator set meets NFPA 110, Level 1, when equipped with the necessary accessories and installed per NFPA standards.
- The generator set complies with ISO 8528-5, Class G2, requirements for transient performance in all generator set configurations. Select the Decision-Maker™ 550 controller for improved voltage regulation and ISO 8528-5, Class G3, compliance.
- The generator set engine is certified by the Environmental Protection Agency (EPA) to conform to interim Tier 4 nonroad emissions regulations.
- A one-year limited warranty covers all systems and components. Two-, five-, and ten-year extended warranties are also available.
- Alternator features:
  - The unique Fast-Response™ II excitation system delivers excellent voltage response and short circuit capability using a permanent magnet (PM)-excited alternator.
  - The brushless, rotating-field alternator has broadrange reconnectability.
- Other features:
  - Controllers are available for all applications. See controller features inside.
  - The low coolant level shutdown prevents overheating (standard on radiator models only).
  - Integral vibration isolation eliminates the need for under-unit vibration spring isolators.

**Generator Set Ratings**

| Alternator | Voltage | Ph | Hz | 130° C Rise Standby Rating |      | 105° C Rise Prime Rating |      |
|------------|---------|----|----|----------------------------|------|--------------------------|------|
|            |         |    |    | kW/kVA                     | Amps | kW/kVA                   | Amps |
| 4P5        | 120/208 | 3  | 60 | 30/38                      | 104  | 25/31                    | 87   |
|            | 127/220 | 3  | 60 | 30/38                      | 98   | 25/31                    | 82   |
|            | 120/240 | 3  | 60 | 30/38                      | 90   | 25/31                    | 75   |
|            | 120/240 | 1  | 60 | 27/27                      | 113  | 24/24                    | 100  |
|            | 139/240 | 3  | 60 | 30/38                      | 90   | 25/31                    | 75   |
|            | 220/380 | 3  | 60 | 30/38                      | 57   | 25/31                    | 47   |
|            | 277/480 | 3  | 60 | 30/38                      | 45   | 25/31                    | 38   |
|            | 347/600 | 3  | 60 | 30/38                      | 36   | 25/31                    | 30   |
| 4P7        | 120/208 | 3  | 60 | 30/38                      | 104  | 26/33                    | 90   |
|            | 127/220 | 3  | 60 | 30/38                      | 98   | 26/33                    | 85   |
|            | 120/240 | 3  | 60 | 30/38                      | 90   | 26/33                    | 78   |
|            | 120/240 | 1  | 60 | 28/28                      | 117  | 25/25                    | 104  |
|            | 139/240 | 3  | 60 | 30/38                      | 90   | 26/33                    | 78   |
|            | 220/380 | 3  | 60 | 30/38                      | 57   | 26/33                    | 49   |
|            | 277/480 | 3  | 60 | 30/38                      | 45   | 26/33                    | 39   |
|            | 347/600 | 3  | 60 | 30/38                      | 36   | 26/33                    | 31   |
| 4Q4        | 120/240 | 1  | 60 | 28/28                      | 117  | 25/25                    | 104  |

RATINGS: All three-phase units are rated at 0.8 power factor. All single-phase units are rated at 1.0 power factor. *Standby Ratings:* Standby ratings apply to installations served by a reliable utility source. The standby rating is applicable to varying loads for the duration of a power outage. There is no overload capability for this rating. Ratings are in accordance with ISO-3046/1, BS 5514, AS 2789, and DIN 6271. *Prime Power Ratings:* Prime power ratings apply to installations where utility power is unavailable or unreliable. At varying load, the number of generator set operating hours is unlimited. A 10% overload capacity is available for one hour in twelve. Ratings are in accordance with ISO-8528/1, overload power in accordance with ISO-3046/1, BS 5514, AS 2789, and DIN 6271. For limited running time and base load ratings, consult the factory. Obtain the technical information bulletin (TIB-101) on ratings guidelines for the complete ratings definitions. The generator set manufacturer reserves the right to change the design or specifications without notice and without any obligation or liability whatsoever. GENERAL GUIDELINES FOR DERATION: *Altitude:* Derate 0.5% per 100 m (328 ft.) elevation above 2100 m (6890 ft.). *Temperature:* Derate 1.0% per 10° C (18° F) temperature above 25° C (77° F).

# Alternator Specifications

| Specifications  | Alternator                    |
|---|-------------------------------|
| Manufacturer  | Kohler                        |
| Type  | 4-Pole, Rotating-Field        |
| Exciter type  | Brushless, Permanent-Magnet   |
| Leads: quantity, type   | 12, Reconnectable             |
| Voltage regulator   | Solid State, Volts/Hz         |
| Insulation:   | NEMA MG1                      |
| Material  | Class H                       |
| Temperature rise  | 130°C, Standby                |
| Bearing: quantity, type                                       | 1, Sealed                     |
| Coupling  | Flexible Disc                 |
| Amortisseur windings  | Full                          |
| Voltage regulation, no-load to full-load                      |                               |
| Permanent magnet (PM) alternator                              | ±2% Average                   |
| 550 controller (with 0.5% drift due to temperature variation) | 3-Phase Sensing, ±0.25%       |
| One-step load acceptance                                      | 100% of Rating                |
| Unbalanced load capability                                    | 100% of Rated Standby Current |
| Peak motor starting kVA:                                      | (35% dip for voltages below)  |
| 480 V 4P5 (12 lead)   | 140                           |
| 480 V 4P7 (12 lead)   | 194                           |
| 240 V 4Q4 (4 lead)  | 72                            |

- NEMA MG1, IEEE, and ANSI standards compliance for temperature rise and motor starting.
- Sustained short-circuit current of up to 300% of the rated current for up to 10 seconds.
- Sustained short-circuit current enabling downstream circuit breakers to trip without collapsing the alternator field.
- Self-ventilated and drip-proof construction.
- Vacuum-impregnated windings with fungus-resistant epoxy varnish for dependability and long life.
- Superior voltage waveform from a two-thirds pitch stator and skewed rotor.
- Fast-Response™ II brushless alternator with brushless exciter for excellent load response.

## Application Data

### Engine

| Engine Specifications                      |                                 |
|--|---------------------------------|
| Manufacturer                               | John Deere                      |
| Engine model                               | 4024TF281                       |
| Engine type                                | 4-Cycle, Turbocharged           |
| Cylinder arrangement                       | 4 Inline                        |
| Displacement, L (cu. in.)                  | 2.4 (149)                       |
| Bore and stroke, mm (in.)                  | 86 x 105 (3.39 x 4.13)          |
| Compression ratio                          | 20.5:1                          |
| Piston speed, m/min. (ft./min.)            | 375 (1230)                      |
| Main bearings: quantity, type              | 5, Replaceable Insert           |
| Rated rpm                                  | 1800                            |
| Max. power at rated rpm, kWm (BHP)         | 49 (66)                         |
| Cylinder head material                     | Cast Iron                       |
| Crankshaft material                        | Ductile Iron                    |
| Valve material:                            |                                 |
| Intake                                     | Chromium-Silicon Steel          |
| Exhaust                                    | Stainless Steel                 |
| Governor: type, make/model                 | Electronic, Stanadyne/Unit Pump |
| Frequency regulation, no-load to full-load | Isochronous                     |
| Frequency regulation, steady state         | ±0.25%                          |
| Frequency                                  | Fixed                           |
| Air cleaner type, all models               | Dry                             |

### Exhaust

| Exhaust System  |            |
|---|------------|
| Exhaust manifold type                                 | Dry        |
| Exhaust flow at rated kW, m <sup>3</sup> /min. (cfm)  | 8.0 (283)  |
| Exhaust temperature at rated kW, dry exhaust, °C (°F) | 552 (1026) |
| Maximum allowable back pressure, kPa (in. Hg)         | 7.5 (2.2)  |
| Exhaust outlet size at engine hookup, mm (in.)        | 63.5 (2.5) |

### Engine Electrical

| Engine Electrical System                       |  |          |
|--|--|----------|
| Battery charging alternator:                   |  |          |
| Ground (negative/positive)                     |  | Negative |
| Volts (DC)                                     |  | 12       |
| Ampere rating                                  |  | 70       |
| Starter motor rated voltage (DC)               |  | 12       |
| Battery, recommended cold cranking amps (CCA): |  |          |
| Quantity, CCA rating                           |  | One, 640 |
| Battery voltage (DC)                           |  | 12       |

### Fuel

| Fuel System                                 |  |                            |
|---|--|----------------------------|
| Fuel supply line, min. ID, mm (in.)         |  | 11.0 (0.44)                |
| Fuel return line, min. ID, mm (in.)         |  | 6.0 (0.25)                 |
| Max. lift, engine-driven fuel pump, m (ft.) |  | 3.0 (10.0)                 |
| Max. fuel flow, Lph (gph)                   |  | 99 (26.1)                  |
| Fuel prime pump                             |  | Manual                     |
| Fuel filter                                 |  |                            |
| Secondary                                   |  | 5 Microns @ 98% Efficiency |
| Water Separator                             |  | Yes                        |
| Recommended fuel                            |  | #2 Diesel                  |

### Lubrication

| Lubricating System                    |               |
|---------------------------------------|---------------|
| Type                                  | Full Pressure |
| Oil pan capacity, L (qt.)             | 7.3 (7.7)     |
| Oil pan capacity with filter, L (qt.) | 8.2 (8.7)     |
| Oil filter: quantity, type            | 1, Cartridge  |
| Oil cooler                            | Water-Cooled  |

## Application Data

### Cooling

#### Radiator System

|  |             |
|--|-------------|
| Ambient temperature, °C (°F)   | 50 (122)    |
| Engine jacket water capacity, L (gal.)   | 2.6 (0.7)   |
| Radiator system capacity, including engine, L (gal.)   | 11.4 (3.0)  |
| Engine jacket water flow, Lpm (gpm)  | 91 (24)     |
| Heat rejected to cooling water at rated kW, dry exhaust, kW (Btu/min.)                             | 24.8 (1412) |
| Water pump type  | Centrifugal |
| Fan diameter, including blades, mm (in.)   | 597 (23.5)  |
| Fan, kWm (HP)  | 2.9 (3.9)   |
| Max. restriction of cooling air, intake and discharge side of radiator, kPa (in. H <sub>2</sub> O) | 0.125 (0.5) |

#### Remote Radiator System†

|  |           |
|--|-----------|
| Exhaust manifold type  | Dry       |
| Connection sizes:  |           |
| Water inlet, ID hose, mm (in.)                                 | 51 (2.00) |
| Water outlet, ID hose, mm (in.)                                | 48 (1.88) |
| Static head allowable above engine, kPa (ft. H <sub>2</sub> O) | 63 (21)   |

† Contact your local distributor for cooling system options and specifications based on your specific application.

### Operation Requirements

#### Air Requirements

|   |           |
|---|-----------|
| Radiator-cooled cooling air, m <sup>3</sup> /min. (scfm)‡   | 96 (3400) |
| Cooling air required for generator set when equipped with city water cooling or remote radiator, based on 14°C (25°F) rise and ambient temp. of 29°C (85°F), m <sup>3</sup> /min. (cfm) | 48 (1700) |
| Combustion air, m <sup>3</sup> /min. (cfm)  | 3.0 (106) |
| Heat rejected to ambient air:   |           |
| Engine, kW (Btu/min.)   | 8.6 (490) |
| Alternator, kW (Btu/min.)   | 4.4 (250) |

‡ Air density = 1.20 kg/m<sup>3</sup> (0.075 lbm/ft<sup>3</sup>)

#### Fuel Consumption

| Diesel, Lph (gph) at % load | Standby Rating |       |
|-----------------------------|----------------|-------|
| 100%                        | 10.6           | (2.8) |
| 75%                         | 8.0            | (2.1) |
| 50%                         | 5.8            | (1.5) |
| 25%                         | 3.9            | (1.0) |
| Diesel, Lph (gph) at % load | Prime Rating   |       |
| 100%                        | 9.4            | (2.5) |
| 75%                         | 7.2            | (1.9) |
| 50%                         | 5.2            | (1.4) |
| 25%                         | 3.4            | (0.9) |

## Controllers

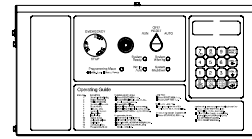

#### Decision-Maker™ 550 Controller

Audiovisual annunciation with NFPA 110 Level 1 capability. Programmable microprocessor logic and digital display features. Alternator safeguard circuit protection. 12- or 24-volt engine electrical system capability. Remote start, remote annunciation, and remote communication options. Refer to G6-46 for additional controller features and accessories.

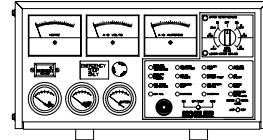

#### Decision-Maker™ 3+, 16-Light Controller

Audiovisual annunciation with NFPA 110 Level 1 capability. Microprocessor logic, AC meters, and engine gauge features. 12- or 24-volt engine electrical system capability. Remote start, prime power, and remote annunciation options. Refer to G6-30 for additional controller features and accessories.

## Additional Standard Features

- Alternator Protection (standard with 550 controller)
- Battery Rack and Cables
- Integral Vibration Isolation
- Oil Drain and Coolant Drain w/Hose Barb
- Oil Drain Extension (with narrow skid and enclosure models only)
- Operation and Installation Literature
- Radiator Drain Extension with Enclosure Only

## Available Accessories

### Enclosed Unit

- Sound Enclosure (with enclosed critical silencer)
- Weather Enclosure (with enclosed critical silencer)

### Open Unit

- Exhaust Silencer, Critical (kit: PA-352663)
- Exhaust Silencer, Hospital (kit: GM32386-KP1)
- Flexible Exhaust Connector, Stainless Steel

### Cooling System

- Block Heater  
(recommended for ambient temperatures below 0°C [32°F])
- Radiator Duct Flange
- Remote Radiator Cooling

### Fuel System

- Auxiliary Fuel Pump
- Flexible Fuel Lines
- Fuel Pressure Gauge
- Subbase Fuel Tanks

### Electrical System

- Battery
- Battery Charger, Equalize/Float Type
- Battery Heater

### Engine and Alternator

- Air Cleaner, Heavy Duty
- Air Cleaner Restriction Indicator
- Alternator Strip Heater
- Bus Bar Kits
- Closed Crankcase Vent
- CSA Certification
- Current Transformer Kit
- Line Circuit Breaker (NEMA type 1 enclosure)
- Line Circuit Breaker with Shunt Trip (NEMA type 1 enclosure)
- Optional Alternators
- Rated Power Factor Testing
- Rodent Guards
- Safeguard Breaker (not available with 550 controller)
- Skid End Caps

### Paralleling System

- Reactive Droop Compensator
- Voltage Adjust Control
- Voltage Regulator Relocation Kit

### Maintenance

- General Maintenance Literature Kit
- Maintenance Kit (includes standard air, oil, and fuel filters)
- NFPA 110 Literature
- Overhaul Literature Kit
- Production Literature Kit

### Controller (550 and 16-Light Controllers)

- Common Failure Relay Kit
- Communication Products and PC Software (550 controller only)
- Customer Connection Kit
- Dry Contact Kit (isolated alarm)
- Engine Prealarm Sender Kit
- Prime Power Switch (550 controller only)
- Remote Annunciator Panel
- Remote Audiovisual Alarm Panel
- Remote Emergency Stop Kit
- Remote Mounting Cable
- Run Relay Kit

### Miscellaneous Accessories

- \_\_\_\_\_
- \_\_\_\_\_
- \_\_\_\_\_
- \_\_\_\_\_

## Dimensions and Weights

Overall Size, L x W x H, mm (in.):  
 Wide Skid: 2300 x 1040 x 1133 (90.55 x 40.94 x 44.61)  
 Narrow Skid: 1998 x 780 x 1067 (78.66 x 30.71 x 42.01)  
 Weight (radiator model), wet, kg (lb.): 735 (1620)

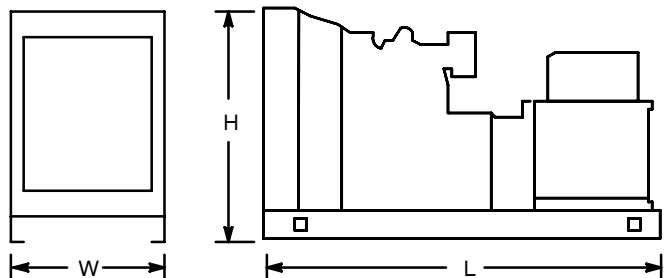

NOTE: This drawing is provided for reference only and should not be used for planning installation. Contact your local distributor for more detailed information.

## DISTRIBUTED BY: