

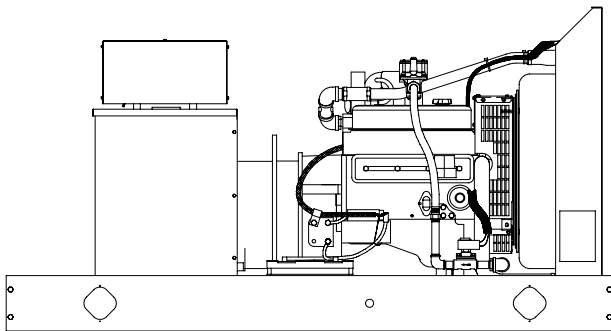

Ratings Range

		60 Hz
Standby:	kW	27-32
	kVA	27-40
Prime:	kW	24-29
	kVA	24-36



Standard Features

- Kohler Co. provides one-source responsibility for the generating system and accessories.
- The generator set and its components are prototype-tested, factory-built, and production-tested.
- The 60 Hz generator set offers a UL 2200 listing.
- The generator set accepts rated load in one step.
- The 60 Hz generator set meets NFPA 110, Level 1, when equipped with the necessary accessories and installed per NFPA standards.
- A one-year limited warranty covers all systems and components. Two-, five-, and ten-year extended warranties are also available.
- Alternator features:
 - The unique Fast-Response™ II excitation system delivers excellent voltage response and short circuit capability using a permanent magnet (PM)-excited alternator.
 - The brushless, rotating-field alternator has broadrange reconnectability.
- Other features:
 - Controllers are available for all applications. See controller features inside.
 - The electronic, isochronous governor incorporates an integrated drive-by-wire throttle body actuator delivering precise frequency regulation.

Generator Set Ratings

Alternator	Voltage	Ph	Hz	Natural Gas				LP Gas			
				130° C Rise Standby Rating		105° C Rise Prime Rating		130° C Rise Standby Rating		105° C Rise Prime Rating	
				kW/kVA	Amps	kW/kVA	Amps	kW/kVA	Amps	kW/kVA	Amps
4P5	120/208	3	60	30/38	104	27/34	94	32/40	111	29/36	101
	127/220	3	60	30/38	98	27/34	89	32/40	105	29/36	95
	120/240	3	60	30/38	90	27/34	81	32/40	96	29/36	87
	120/240	1	60	27/27	113	24/24	100	29/29	121	26/26	108
	139/240	3	60	30/38	90	27/34	81	32/40	96	29/36	87
	220/380	3	60	30/38	57	27/34	51	32/40	61	29/36	55
	277/480	3	60	30/38	45	27/34	41	32/40	48	29/36	44
	347/600	3	60	30/38	36	27/34	32	32/40	38	29/36	35
4P7B	120/208	3	60	30/38	104	27/34	94	32/40	111	29/36	101
	127/220	3	60	30/38	98	27/34	89	32/40	105	29/36	95
	120/240	3	60	30/38	90	27/34	81	32/40	96	29/36	87
	120/240	1	60	27/27	113	24/24	100	29/29	121	26/26	108
	139/240	3	60	30/38	90	27/34	81	32/40	96	29/36	87
	220/380	3	60	30/38	57	27/34	51	32/40	61	29/36	55
	277/480	3	60	30/38	45	27/34	41	32/40	48	29/36	44
	347/600	3	60	30/38	36	27/34	32	32/40	38	29/36	35

RATINGS: All three-phase units are rated at 0.8 power factor. All single-phase units are rated at 1.0 power factor. *Standby Ratings:* Standby ratings apply to installations served by a reliable utility source. The standby rating is applicable to varying loads for the duration of a power outage. There is no overload capability for this rating. Ratings are in accordance with ISO-3046/1, BS 5514, AS 2789, and DIN 6271. *Prime Power Ratings:* Prime power ratings apply to installations where utility power is unavailable or unreliable. At varying load, the number of generator set operating hours is unlimited. A 10% overload capacity is available for one hour in twelve. Ratings are in accordance with ISO-8528/1, overload power in accordance with ISO-3046/1, BS 5514, AS 2789, and DIN 6271. For limited running time and base load ratings, consult the factory. Obtain the technical information bulletin (TIB-101) on ratings guidelines for the complete ratings definitions. The generator set manufacturer reserves the right to change the design or specifications without notice and without any obligation or liability whatsoever. GENERAL GUIDELINES FOR DERATION: *Altitude:* Derate 1.3% per 100 m (328 ft.) elevation above 200 m (656 ft.). *Temperature:* Derate 3.0% per 10°C (18°F) temperature above 40°C (104°F).

Alternator Specifications

Specifications	Alternator
Manufacturer	Kohler
Type	4-Pole, Rotating-Field
Exciter type	Brushless, Permanent-Magnet
Leads: quantity, type	12, Reconnectable
Voltage regulator	Solid State, Volts/Hz
Insulation:	NEMA MG1
Material	Class H
Temperature rise	130°C, Standby
Bearing: quantity, type	1, Sealed
Coupling	Flexible Disc
Amortisseur windings	Full
Voltage regulation, no-load to full-load	
Permanent magnet (PM) alternator	±2% Average
550 controller (with 0.5% drift due to temperature variation)	3-Phase Sensing, ±0.25%
Unbalanced load capability	100% of Rated Standby Current
One-step load acceptance	100% of Rating
Peak motor starting kVA:	(35% dip for voltages below)
480 V 4P5 (12 lead)	140
480 V 4P7B (12 lead)	175

- NEMA MG1, IEEE, and ANSI standards compliance for temperature rise and motor starting.
- Sustained short-circuit current of up to 300% of the rated current for up to 10 seconds.
- Sustained short-circuit current enabling downstream circuit breakers to trip without collapsing the alternator field.
- Self-ventilated and drip-proof construction.
- Vacuum-impregnated windings with fungus-resistant epoxy varnish for dependability and long life.
- Superior voltage waveform from a two-thirds pitch stator and skewed rotor.
- Fast-Response™ II brushless alternator with brushless exciter for excellent load response.

Application Data

Engine

Engine Specifications	
Manufacturer	General Motors
Engine: model, type	Industrial Powertrain 3.0 L, 4-Cycle Natural Aspiration
Cylinder arrangement	4 Inline
Displacement, L (cu. in.)	3.0 (181)
Bore and stroke, mm (in.)	101.6 x 91.4 (4.00 x 3.60)
Compression ratio	8.2:1
Piston speed, m/min. (ft./min.)	329 (1080)
Main bearing caps	2 Bolt
Rated rpm	1800
Max. power at rated rpm, kW (HP)	40 (54)
Engine power at standby rating, kW (HP)	40 (54)
Cylinder head material	Cast Iron
Piston type and material	High Silicon Aluminum
Crankshaft material	Nodular Iron
Governor type	Electronic
Frequency regulation, no-load to full-load	Isochronous
Frequency regulation, steady state	±0.5%
Air cleaner type, all models	Dry

Exhaust

Exhaust System	
Exhaust manifold type	Dry
Exhaust flow at rated kW, m ³ /min. (cfm)	7.1 (250)
Exhaust temperature at rated kW, dry exhaust, °C (°F)	566 (1050)
Maximum allowable back pressure, kPa (in. Hg)	10.2 (3.0)
Exhaust outlet size at engine hookup, mm (in.)	64 (2.5) OD

Engine Electrical

Engine Electrical System	
Ignition system	Electronic, Distributor
Battery charging alternator:	
Ground (negative/positive)	Negative
Volts (DC)	12
Ampere rating	70
Starter motor rated voltage (DC)	12
Battery, recommended cold cranking amps (CCA):	
Qty., rating for -18°C (0°F)	1, 630
Battery voltage (DC)	12

Fuel

Fuel System	
Fuel type	LP Gas or Natural Gas
Fuel supply line inlet	1 NPTF
Natural gas/LPG fuel supply pressure, measured at the generator set fuel inlet after any fuel system equipment accessories, kPa (in. H ₂ O)	1.74–2.74 (7.0–11.0)

Fuel Composition Limits *	Nat. Gas	LP Gas
Methane, % by volume	90 min.	—
Ethane, % by volume	4.0 max.	—
Propane, % by volume	1.0 max.	85 min.
Propene, % by volume	0.1 max.	5.0 max.
C ₄ and higher, % by volume	0.3 max.	2.5 max.
Sulfur, ppm mass	25 max.	
Lower heating value, kJ/m ³ (Btu/ft ³), min.	26.6 (890)	67.5 (2260)

* Fuels with other compositions may be acceptable. If your fuel is outside the listed specifications, contact your local distributor for further analysis and advice.

Application Data

Lubrication

Lubricating System	
Type	Full Pressure
Oil pan capacity, L (qt.)	3.8 (4.0)
Oil pan capacity with filter, L (qt.)	4.1 (4.3)
Oil filter: quantity, type	1, Cartridge

Cooling

Radiator System	
Ambient temperature, °C (°F)*	50 (122)
Engine jacket water capacity, L (gal.)	6.8 (1.8)
Radiator system capacity, including engine, L (gal.)	18.9 (5.0)
Engine jacket water flow, Lpm (gpm)	42 (11)
Heat rejected to cooling water at rated kW, dry exhaust, kW (Btu/min.)	34.1 (1940)
Water pump type	Centrifugal
Fan diameter, including blades, mm (in.)	533 (21)
Fan, kWm (HP)	3.0 (4.0)
Max. restriction of cooling air, intake and discharge side of radiator, kPa (in. H ₂ O)	0.125 (0.5)

* Enclosure with enclosed silencer reduces ambient temperature capability by 5°C (9°F).

Remote Radiator System†

Exhaust manifold type	Dry
Connection sizes:	
Water inlet, ID hose, mm (in.)	50.8 (2.00)
Water outlet, ID hose, mm (in.)	44.5 (1.75)
Static head allowable above engine, kPa (ft. H ₂ O)	4.32 (17.0)

† Contact your local distributor for cooling system options and specifications based on your specific requirements.

Operation Requirements

Air Requirements

Radiator-cooled cooling air, m ³ /min. (scfm)‡	200 (7100)
Cooling air required for generator set when equipped with city water cooling or remote radiator, based on 14°C (25°F) rise, m ³ /min. (cfm)	49 (1735)
Combustion air, m ³ /min. (cfm)	2.1 (74)
Heat rejected to ambient air:	
Engine, kW (Btu/min.)	9.2 (522)
Alternator, kW (Btu/min.)	4.5 (259)

‡ Air density = 1.20 kg/m³ (0.075 lbm/ft³).

Fuel Consumption§

Natural Gas, m ³ /hr. (cfh) at % load	Standby Ratings
100%	12.2 (430)
75%	9.6 (340)
50%	7.2 (255)
25%	5.1 (179)
Natural Gas, m ³ /hr. (cfh) at % load	Prime Ratings
100%	11.2 (394)
75%	8.8 (312)
50%	6.8 (240)
25%	4.8 (171)

LP Gas, m ³ /hr. (cfh) at % load	Standby Ratings
100%	5.0 (175)
75%	4.1 (144)
50%	3.1 (108)
25%	2.1 (74)
LP Gas, m ³ /hr. (cfh) at % load	Prime Ratings
100%	4.6 (163)
75%	3.8 (133)
50%	2.9 (101)
25%	2.0 (71)

§ Fuel consumption is based on 1015 Btu/standard cu. ft. natural gas.

LP vapor conversion factors:

8.58 ft.³ = 1 lb.
0.535 m³ = 1 kg.
36.39 ft.³ = 1 gal.

Controllers

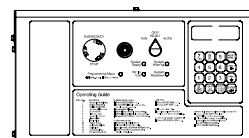

Decision-Maker™ 550 Controller

Audiovisual annunciation with NFPA 110 Level 1 capability. Programmable microprocessor logic and digital display features. Alternator safeguard circuit protection. 12- or 24-volt engine electrical system capability. Remote start, remote annunciation, and remote communication options. Refer to G6-46 for additional controller features and accessories.

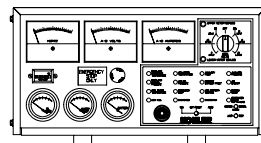

Decision-Maker™ 3+, 16-Light Controller

Audiovisual annunciation with NFPA 110 Level 1 capability. Microprocessor logic, AC meters, and engine gauge features. 12- or 24-volt engine electrical system capability. Remote start, prime power, and remote annunciation options. Refer to G6-30 for additional controller features and accessories.

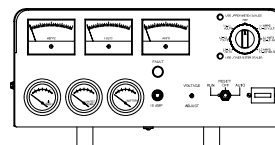

Decision-Maker™ 1 Controller

Single-light annunciation and basic controls with NFPA capability. Relay logic, AC meters, and engine gauge features. 12-volt engine electrical system capability only. Remote or automatic start options. Refer to G6-29 for additional controller features and accessories. **Note:** Not available with 600-volt alternator.

Additional Standard Features

- Alternator Protection (standard with 550 controller)
- Battery Rack and Cables
- Electronic, Isochronous Governor
- Gas Fuel System (includes fuel mixer, secondary gas regulator, gas solenoid valve, and flexible fuel line between the engine and the skid-mounted fuel system components)
- Integral Vibration Isolation
- Oil Drain Extension
- Operation and Installation Literature

Available Accessories

Enclosed Unit

- Sound Enclosure (with enclosed critical silencer)
- Weather Enclosure (with enclosed critical silencer)
- Weather Housing (with roof-mounted critical silencer)

Open Unit

- Exhaust Silencer, Critical (kits: PA-324468, PA-352663)
- Flexible Exhaust Connector, Stainless Steel

Cooling System

- Block Heater
[recommended for ambient temperatures below 10°C (50°F)]
- City Water Cooling
- Radiator Duct Flange
- Remote Radiator Cooling

Fuel System

- Flexible Fuel Line
(required when the generator set skid is spring mounted)
- Gas Filter
- Secondary Gas Solenoid Valve

Electrical System

- Battery
- Battery Charger, Equalize/Float Type
- Battery Heater

Engine and Alternator

- Air Cleaner Restrictor Indicator
- Alternator Strip Heater
- CSA Certification
- Engine Fluids (oil and coolant) Added
- Line Circuit Breaker (NEMA1 enclosure)
- Line Circuit Breaker with Shunt Trip (NEMA1 enclosure)
- Optional Alternators
- Rated Power Factor Testing
- Rodent Guards
- Safeguard Breaker (not available with 550 controller)
- Voltage Regulation, 1%
- Voltage Regulator Sensing, Three-Phase

Literature and Maintenance

- General Maintenance Literature Kit
- Maintenance Kit (includes standard air, oil, and fuel filters)
- NFPA 110 Literature
- Overhaul Literature Kit
- Production Literature Kit

Controller (550 and 16-Light)

- Common Failure Relay Kit
- Communication Products and PC Software (550 controller only)
- Customer Connection Kit
- Dry Contact Kit (isolated alarm)
- Engine Prealarm Sender Kit
- Local Emergency Stop Kit
- Prime Power Switch (550 controller only)
- Remote Annunciator Panel
- Remote Audiovisual Alarm Panel
- Remote Emergency Stop Kit
- Remote Mounting Cable
- Run Relay Kit

Miscellaneous Accessories

- _____
- _____
- _____
- _____
- _____
- _____
- _____
- _____
- _____
- _____
- _____
- _____
- _____
- _____
- _____

Dimensions and Weights

Overall Size, L x W x H, mm (in.):
 Wide Skid 2200 x 1040 x 1172 (86.6 x 40.9 x 46.1)
 Narrow Skid 2200 x 865 x 1172 (86.6 x 34.0 x 46.1)
 Weight (radiator model), wet, kg (lb.): 573 (1260)

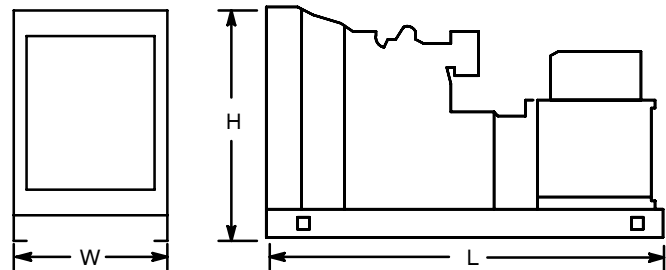

NOTE: This drawing is provided for reference only and should not be used for planning installation. Contact your local distributor for more detailed information.

DISTRIBUTED BY: