

**AUTOMATIC TRANSFER SWITCHES**



**TS 880 - 1200 AMP  
TRANSFER SWITCH**



**TS 880-2500 AMP  
TRANSFER SWITCH**



**THOMSON TECHNOLOGY TS 880 AUTOMATIC TRANSFER SWITCHES  
OFFER THE FOLLOWING OUTSTANDING FEATURES:**

**Enclosed Contact Power Switching Units**

- **fully enclosed** silver alloy contacts provide **high withstand** rating & **100% continuous** current rating.
- **3 cycle short circuit current withstand** tested allows use of non-series rated upstream protection devices.
- **completely separate** utility and generator side power switching units provide superior reliability through redundancy (no common parts), as well as excellent serviceability.
- power switching units can incorporate **over current protection**, allowing cost savings in upstream devices.
- **not damaged if manually switched** while in service since contacts have inherent stored energy design.

**Reliable Motor-Operated Transfer Mechanism**

- **heavy duty** brushless gearmotor and operating mechanism provide mechanical interlocking and extreme long life with minimal maintenance.
- **safe manual operation** permits easy operation even under adverse conditions.

**Superior Serviceability**

- all mechanical and control devices are **visible and readily accessible**.

**Control Features**

- **TSC 800** microprocessor based controller with comprehensive features and state of the art design.
- **isolation plug** permits disconnecting control circuits from all power sources for safety and convenience.

**Quality Assurance**

- ISO 9001:2000 Registered

**Product Data**

- Models available from 100 - 4000 Amp continuous
- Available 2, 3 or 4 pole
- All models 50/60Hz rated
- Voltage range 208 - 600
- 3 Phase, 3 or 4 wire systems

**Safety Standards**

- UL 1008 Automatic Transfer Switches for use in Emergency Systems
- CSA C22.2 No. 178 Automatic Transfer Switches

## GENERAL DESCRIPTION

### STANDARD ATS

**Thomson Technology TS 880 Standard Automatic Transfer Switches** employ two mechanically interlocked power switching units with a microprocessor based controller to automatically start a generator and transfer system load to a generator supply in the event of a utility supply failure. System load is then automatically retransferred back to the utility supply following restoration of the utility power source to within normal operating limits. All load transfer sequences are "Open Transition" (i.e. "break-before-make") with adjustable neutral position unless the Closed Transition option is supplied with the transfer switch.

**TS 880** Automatic Transfer Switches are specifically designed and certified to CSA C22.2 No. 178 & UL 1008 Standards for use in Emergency Power System applications such as commercial, industrial, or government institutions that require automatic standby power.

All **TS 880** transfer switch models have been 3 cycle withstand current tested in accordance with UL 1008 & CSA 178 which allow high current ratings and use of non-series rated upstream protective devices.

The standard **TS 880** Automatic Transfer Switch is rated for 100% system load and requires upstream over current protection. The **TS 880** design allows optional use of integral over current trip elements within the power switching units thus eliminating the need for external, upstream over current protection.

The **TS 880** series transfer switches use a type **TSC 800** microprocessor based controller. All necessary control functions for fully automatic operation are provided by the **TSC 800** transfer controller. The **TSC 800** controller is mounted on the door of the transfer switch enclosure and operating status is shown via faceplate mounted LED lights and LCD display.

### MANUAL TRANSFER SWITCH

**Thomson Technology TS 880 Standard Automatic Transfer Switches** are also available in a Manually Initiated configuration without the TSC 800 controller but providing Source Availability and Position indication lights with a Source 1/ Source 2 selector switch. Transfer switches with this option

or options that inhibit the automatic transfer to the emergency source are labeled "non-automatic" in accordance with UL 1008 and CSA C22.2 No. 178 requirements.

### SERVICE ENTRANCE ATS

**Thomson Technology TS 880 Service Entrance Automatic Transfer Switches** incorporate an isolating mechanism and over current protection on the utility supply thereby removing the need to have a separate, upstream circuit breaker/disconnect switch from the transfer switch. This unique **Service Entrance Rated Automatic Transfer Switch** design is incorporated into a standard sized automatic transfer switch enclosure providing a space saving, cost effective solution for most applications.

The **Service Entrance Rated ATS** feature is a standard option that can be applied to any **TS 880** model of Thomson Technology Transfer Switch.

Standard features of the **Service Entrance Rated Automatic Transfer Switch** include a NEMA 1 rated enclosure, pad-lockable Service Disconnect control switch and status indications.

**TS 880 SE** Service disconnect operation is simple and ensures a high level of safety for system maintenance personnel.

Normal operation and performance of the automatic transfer switch is unaffected by the Service Entrance ATS feature.

**TS 880 SE** Automatic Transfer Switches are specifically designed and certified to the UL 1008 Standard as well as complying with NEC and NFPA requirements. **TS 880 SE** Automatic Transfer Switches are for use in Emergency Power System applications such as commercial, industrial, or government institutions that require automatic standby power.

All **TS 880 SE** transfer switch models have been 3 cycle withstand current tested in accordance with UL 1008 & CSA 178 which allow high current ratings and use of non-series rated upstream protective devices. The **TS 880 SE** Automatic Transfer Switch is rated for the system load and requires upstream over current protection on the generator supply.

The **TS 880 SE** series transfer switches use a type **TSC 800** microprocessor based controller.

## TYPICAL SINGLE LINE DIAGRAM

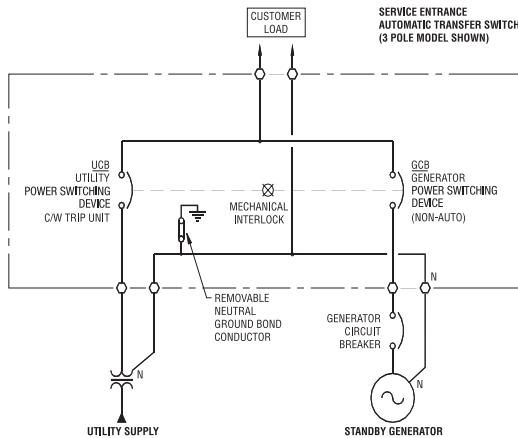

## OPERATION MODE

Service Entrance Automatic Transfer Switch	Utility Power Switching Device	Generator Power Switching Device	ATS Load
Operation Mode	Position	Position	
Normal Conditions (Utility Power Supplying Load)	Closed	Open	Energized
Utility Power Failure (Generator Supplying Load)	Open	Closed	Energized
Service Disconnect Mode	Open (Mechanically & electrically interlocked)	Open (Mechanically & electrically interlocked)	De-Energized

## CLOSED TRANSITION ATS (MOMENTARY)

Thomson Technology TS 880 Closed Transition Automatic Transfer Switches employ two electrically interlocked power switching units and a microprocessor based controller to automatically allow a **Closed Transition** load transfer when both utility and generator sources are available. All **Closed Transition** transfer sequences ensure both sources of power are in synchronism prior to transfer and load is transferred without power interruption. Automatic control & protection circuits ensure the generator and utility supplies are only in parallel for a maximum of 100 milliseconds to permit an uninterrupted load transfer.

In the event of a utility supply failure, the **TS 880 CT** will automatically revert to an Open Transition load transfer sequence to transfer system load automatically to the generator supply. System load is then automatically re-transferred back to the utility supply utilizing a **Closed Transition** transfer sequence following restoration of the utility power source to within normal operating limits. All **Closed Transition** transfer sequences will be inhibited when only one source of power is available.

The **Closed Transition** feature is a standard option that can be applied to **TS 880** models of Thomson Technology Transfer Switches 800A and above utilizing insulated case power switching units.

**TS 880 CT** Automatic Transfer Switches are specifically designed and certified to UL1008 Standards. For use in Emergency Power System applications such as commercial, industrial, or government institutions that require automatic standby power and minimal power interruptions to the load.

All **TS 880 CT** transfer switch models have been 3 cycle withstand current tested in accordance with UL1008 which allow high current ratings and use of non-series rated upstream protective devices.

The standard **TS 880 CT** Automatic Transfer Switch is rated for 100% system load and requires upstream over current protection. The **TS 880 CT** design allows optional use of integral over current trip elements within the power switching units thus eliminating the need for external, upstream protective devices.

The **TS 880 CT** series transfer switches use a type **TSC 800** microprocessor based controller.

## DUAL SOURCE ATS

Thomson Technology TS 880 Dual Source Automatic Transfer Switches employ two mechanically interlocked power switching units with a microprocessor based controller to automatically control two sources of power such as dual utility feeders or dual prime operating generator sets. Upon failure of the preferred operating source, the load will automatically be transferred to the alternate source. System load is then automatically re-transferred back to the preferred operating source following restoration of the power source to within normal operating limits. All load transfer sequences are "Open Transition" (i.e. "break-before-make") with adjustable neutral position delay unless the Closed Transition option (CTT) is supplied with the transfer switch.

**TS 880 DS** Automatic Transfer Switches are specifically

designed and certified to CSA178 & UL1008 Standards for use in Emergency Power System applications such as commercial, industrial, or government institutions.

All **TS 880 DS** transfer switch models have been 3 cycle withstand current tested in accordance with UL1008 & CSA178 which allow high current ratings and use of non-series rated upstream protective devices.

The standard **TS 880 DS** Automatic Transfer Switch is rated for 100% system load and requires upstream over current protection. The **TS 880 DS** design allows optional use of integral over current trip elements within the power switching units thus eliminating the need for external, upstream protective devices.

The **TS 880 DS** series transfer switches use a type **TSC 800** microprocessor based controller.

## BYPASS ISOLATION ATS

**Thomson Technology TS 880 Bypass/Isolation Automatic Transfer Switches** employ a mechanically interlocked power switching mechanism that provides an easy and safe procedure for system maintenance personnel to manually isolate and bypass an automatic transfer switch. The Bypass/Isolation switch is manually operated and allows either generator or utility source to be bypassed to maintain power to the load while the automatic transfer switch is tested for maintenance procedures as required. The bypass/isolation procedure allows a fast, simple and reliable method of isolating and bypassing the automatic transfer switch through a "break-before-make" bypass design. The mechanical interlocking mechanism ensures that the utility and generator sources cannot be paralleled under any circumstance and the transfer switch may be bypassed to either source.

*Note:* Automatic transfer switches rated 800A to 4000A utilizing insulated case switches with a closed transition option may be operated in a "make-before-break" sequence at the operators' discretion.

The **TS 880 Bypass/Isolation Automatic Transfer Switch** is supplied as a single complete assembly with all power conductors provided between the bypass mechanism and the transfer switch. Provisions for all external power cabling for the utility, generator and load conductors are provided for in the bypass/isolation compartment of the switch. The bypass/isolation switch and transfer switch are mounted in separate barriered compartments.

Two unique designs of **TS 880 Bypass/Isolation Automatic Transfer Switch** are utilized which are dependent on the model type and amperage of the transfer switch. For transfer switches rated 100A through 1200A using molded case power switching devices, the bypass isolation mechanism consists of 5 mechanically interlocked power switching devices with operation handle. For transfer switches rated 800A through 4000A using insulated case power switching devices, the bypass isolation mechanism consists of 2 mechanically interlocked power switch devices and draw-out transfer power switch devices with key interlock mechanism. Utilizing independent switching units provides a high degree of reliability and redundancy not available in other switches.

**TS 880 Bypass/Isolation Automatic Transfer Switches** are specifically designed and certified to UL 1008 and CSA 22.2 No. 178 Safety Standards for use in Emergency Power System applications such as commercial, industrial, or government institutions that require automatic standby power.

All **TS 880 Bypass/Isolation Automatic Transfer Switch** models have been 3 cycle withstand current tested in accordance with UL 1008 & CSA 22.2 No. 178 which allow high current ratings and use of non-series rated upstream protective devices.

The standard **TS 880 Bypass/Isolation Automatic Transfer Switch** is rated for 100% system load and requires upstream over current protection.

## TYPICAL SINGLE LINE DIAGRAM

**100A - 1200A Molded Case  
Bypass/Isolation Automatic Transfer Switch**

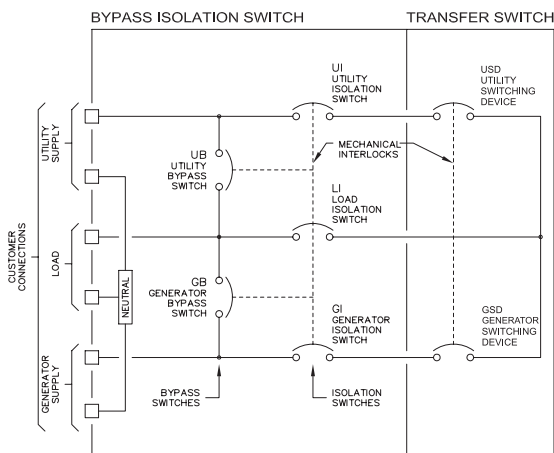

## TYPICAL SINGLE LINE DIAGRAM

**800A - 4000A Insulated Case  
Bypass/Isolation Automatic Transfer Switch**

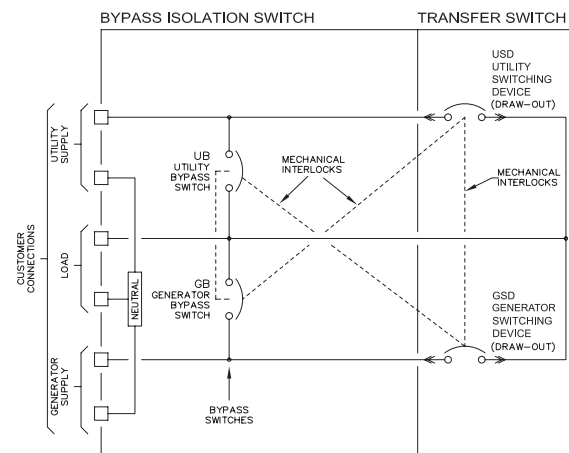

## WITHSTAND CURRENT RATINGS (ALL MODELS)

BASIC MODEL	MAXIMUM VOLTAGE	RATED CURRENT (AMPS)	WITHSTAND CURRENT RATING AMPS (RMS) <sup>1</sup>				
			With Upstream Circuit Breaker Protection			With Upstream Fuse Protection	
			@240V	@480V	@600V	@ up to 600V	FUSE TYPE
TS 88xA - 0100 <sup>1</sup>	600	100	65,000	25,000	18,000	100,000	T,J
TS 88xA - 0150 <sup>1</sup>	600	150	65,000	25,000	18,000	100,000	T,J
TS 88xA - 0200 <sup>1</sup>	240	200	65,000	N/A	N/A	N/A	T,J
TS 88xA - 0250 <sup>1</sup>	600	250	65,000	35,000	25,000	100,000	T,J
TS 88xA - 0400 <sup>1</sup>	600	400	65,000	50,000	35,000	100,000	T,J
TS 88xA - 0600 <sup>1</sup>	600	600	65,000	50,000	35,000	100,000	T,J
TS 88xA - 0800 <sup>1</sup>	600	800	65,000	50,000	35,000	100,000	Consult Factory
TS 88xA - 1000 <sup>1</sup>	600	1000	65,000	50,000	42,000	100,000	Consult Factory
TS 88xA - 1200 <sup>1</sup>	600	1200	65,000	50,000	42,000	100,000	Consult Factory
TS 88xA - 0800 <sup>2</sup>	600	800	100,000	100,000	85,000	100,000	Consult Factory
TS 88xA - 1200 <sup>2</sup>	600	1200	100,000	100,000	85,000	100,000	Consult Factory
TS 88xA - 1600 <sup>2</sup>	600	1600	100,000	100,000	85,000	100,000	Consult Factory
TS 88xA - 2000 <sup>2</sup>	600	2000	100,000	100,000	85,000	100,000	Consult Factory
TS 88xA - 2500 <sup>2</sup>	600	2500	100,000	100,000	85,000	100,000	Consult Factory
TS 88xA - 3000 <sup>2</sup>	600	3000	100,000	100,000	85,000	100,000	Consult Factory
TS 88xA - 4000 <sup>2</sup>	600	4000	100,000	100,000	85,000	100,000	Consult Factory

<sup>1</sup> Note: For Power Switching Devices equipped with optional overcurrent trip units Standard Interrupting ratings are identical to Withstand ratings shown at 240V and 480V systems. For interrupting ratings at 600V contact Thomson Technology.

## ENCLOSURE DIMENSIONS/CABLE TERMINATIONS (ATS only)

BASIC MODEL	DIMENSIONS (Inches) <sup>3</sup>				SHIPPING WEIGHT (lbs)	TERMINAL RATING <sup>4</sup>	
	HEIGHT	WIDTH	DEPTH <sup>5</sup>	DEPTH <sup>6</sup> (Drawout Option)		QTY PER PHASE	RANGE <sup>4</sup>
TS 88xA - 0100 <sup>1</sup>	31	22	14	N/A	143	1	#14 - 1/0
TS 88xA - 0150 <sup>1</sup>	31	22	14	N/A	143	1	#2 - 4/0
TS 88xA - 0200 <sup>1</sup>	31	22	14	N/A	143	1	#6 - 350 MCM
TS 88xA - 0250 <sup>1</sup>	35	27	14	N/A	172	1	#6 - 350 MCM
TS 88xA - 0400 <sup>1</sup>	64	30	13	N/A	387	2	2/0 - 500 MCM
TS 88xA - 0600 <sup>1</sup>	70	34	13	N/A	414	2	2/0 - 500 MCM
TS 88xA - 0800 <sup>1</sup>	70	34	13	N/A	414	3	2/0 - 500 MCM
TS 88xA - 1000 / 1200 <sup>1</sup>	76	34	13	N/A	550	4	4/0 - 500 MCM
TS 88xA - 0800 <sup>2</sup>	91.5	36	42	48	1500	3	#2 - 600 MCM
TS 88xA - 1200 <sup>2</sup>	91.5	36	42	48	1500	4	#2 - 600 MCM
TS 88xA - 1600 <sup>2</sup>	91.5	36	42	48	1500	5	#2 - 600 MCM
TS 88xA - 2000 <sup>2</sup>	91.5	36	42	48	1500	6	#2 - 600 MCM
TS 88xA - 2500 <sup>2</sup>	91.5	36	60	60	1800	7	#2 - 600 MCM
TS 88xA - 3000 <sup>2</sup>	91.5	36	60	60	1800	8	#2 - 600 MCM
TS 88xA - 4000 <sup>2</sup>	91.5	48	72	72	2400	11	#2 - 600 MCM

<sup>1</sup> With molded case power switching devices.

<sup>2</sup> With insulated case power switching devices

<sup>3</sup> Enclosure dimensions are for reference. (DO NOT USE FOR CONSTRUCTION).

<sup>4</sup> All cable connections suitable for copper or aluminum.

<sup>5</sup> Enclosures painted ASA #61grey.

<sup>6</sup> Based on Connection Configuration - A (Standard).

## ENCLOSURE DIMENSIONS/CABLE TERMINATIONS

(ATS with Bypass Switch)

BASIC MODEL	NEMA 1 DIMENSIONS (Inches) <sup>3</sup>								SHIPPING WEIGHT		TERMINAL RATING <sup>4</sup>	
	HEIGHT		WIDTH		DEPTH <sup>6</sup>		DEPTH <sup>6</sup> (Drawout Option)		(lbs)		QTY PER PHASE	RANGE <sup>4</sup>
	3 Pole	4 Pole	3 Pole	4 Pole	3 Pole	4 Pole	3 Pole	4 Pole	3 Pole	4 Pole		
TS 88xB - 0100/0150 <sup>1</sup>	51	51	35	35	14	14	N/A		250	315	1	#2 - 4/0
TS 88xB - 0250 <sup>1</sup>	51	51	35	41	14	14	N/A		360	400	1	#6-350MCM CU/AL
TS 88xB - 0400 <sup>1</sup>	72	72	60	60	16	16	N/A		1100	1225	2	2/0-500MCM CU/AL
TS 88xB - 0600 <sup>1</sup>	72	72	60	60	16	16	N/A		1100	1225	2	2/0-500MCM CU/AL
TS 88xB - 0800 <sup>1</sup>	72	72	60	60	16	16	N/A		1190	1325	3	2/0-500MCM CU/AL
TS 88xB - 1000/1200 <sup>1</sup>	92	92	42	42	36	36	N/A		1480	1650	4	4/0-500MCM CU/AL
TS 88xB - 0800 <sup>2</sup>	92	92	72	72	-	-	48	48	3000	3100	3	#2 - 600 MCM
TS 88xB - 1200 <sup>2</sup>	92	92	72	72	-	-	48	48	3000	3100	4	#2 - 600 MCM
TS 88xB - 1600 <sup>2</sup>	92	92	72	72	-	-	48	48	3000	3100	5	#2 - 600 MCM
TS 88xB - 2000 <sup>2</sup>	92	92	72	72	-	-	54	54	3000	3100	6	#2 - 600 MCM
TS 88xB - 2500 <sup>2</sup>	92	92	72	72	-	-	66	66	3600	3750	7	#2 - 600 MCM
TS 88xB - 3000 <sup>2</sup>	92	92	72	72	-	-	66	66	3600	3750	8	#2 - 600 MCM
TS 88xB - 4000 <sup>2</sup>	92	92	84	84	-	-	72	72	4800	5000	11	#2 - 600 MCM

Optional NEMA 2, 3R & 4X class enclosures available — consult Thomson Technology.

<sup>1</sup> With molded case power switching devices.

<sup>2</sup> With insulated case power switching devices

<sup>3</sup> Enclosure dimensions are for reference. (DO NOT USE FOR CONSTRUCTION).

<sup>4</sup> All cable connections suitable for copper or aluminum.

<sup>5</sup> Enclosures painted ASA #61grey.

<sup>6</sup> Enclosure depth shown has cable entry/exit location restrictions.  
Contact Factory for further detailed information.

## STANDARD FEATURES

Programmable/Multi-Tap System Voltage Selection\*\*  
 Load on Utility & Load on Generator Lights c/w Lamp Test  
 3 Phase Voltage Sensing on Utility & Generator Sources  
 Under/Over Frequency Sensor on Generator Source (with Adjustable Time Delay)  
 Under/Over Frequency Sensor on Utility Source (with Adjustable Time Delay)  
 Over Voltage 3 Phase Sensor on both Utility and Generator Sources  
 TSC 800 Remote Communication Port (RS422). Can be used in Conjunction with External Communication Interface Module\* (CIM Module Not Included).  
 Digital 3 Phase Metering of Voltage & Frequency on Utility & Generator Sources  
 Phase Balance (Utility & Generator Source)  
 Engine Start Delay Timer  
 Engine Cooldown Delay Timer  
 Engine Warm-Up Timer  
 Neutral Position Delay  
 Utility Return Timer  
 Exercise Timer 7, 14, 21 or 28 Day  
 Data Logging  
 Programmable Function Output Contact\*\*\*  
 Diagnostic LED's  
 Backlit TSC 800 LCD Display

NEMA 1 Enclosure  
 Solid Neutral  
 ATS Four Position Mode Selection (Security Protected)

- Automatic
- Off
- No Load Test
- Full Load Test

Auxiliary Contact - Utility Side (Qty 3)

Auxiliary Contact - Generator Side (Qty 3)

Provision for Remote Load Test/Peak Shave Switch Input

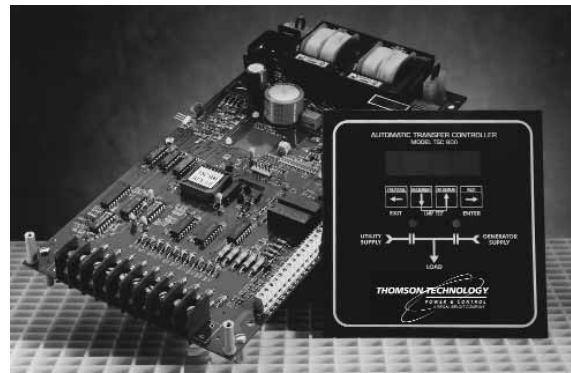

\* Refer to Separate Literature

\*\* Excludes TS 880-200 and all 2 pole models

\*\*\* Not available with Dual Source (DS) option

THOMSON TECHNOLOGY • 9087A - 198th STREET, LANGLEY, BC CANADA V1M 3B1

TELEPHONE: (604) 888-0110 • FAX: (604) 888-3381 • E-MAIL: info@thomsontechnology.com • www.thomsontechnology.com

# ORDERING INFORMATION

Specify the following 21 digit ATS MODEL CODE as per the features & applications described below.

1	2	4	5	6	7	8	9	10	11	12	13	14	15	16	17	18	19	20	21	
T	S	8	8																	

### 1-3. SERIES

TS – TRANSFER SWITCH

### 4 & 5. MODEL

88 – 880 SWITCH

### 6. POLES

2 – 2 POLE  
3 – 3 POLE  
4 – 4 POLE

### 7. CONFIGURATION TYPE

A – ATS  
B – BYPASS/ISOLATION ATS  
X – SPECIAL

### 8-11. AMPERAGE

0100  
0150  
0200  
0250  
0400  
0600  
0800  
1000  
1200  
1600  
2000  
2500  
3000  
4000

### 12. APPLICATION

A – STANDARD  
B – SERVICE ENTRANCE  
C – DUAL SOURCE  
D – DUAL SOURCE STANDBY  
X – SPECIAL

### 13. OPERATION TYPE

1 – OPEN TRANSITION  
2 – MANUAL ELEC. OP.  
3 – CLOSED TRANSITION (MOMENTARY)  
4 – CLOSED TRANSITION (SOFT LOAD)  
X – SPECIAL

### 14. SAFETY STANDARD

A – UL 1008  
B – CSA C22.2. No. 178  
X – NOT APPLICABLE

### 15. VOLTAGE

**1Ø 3 WIRE**  
D – 120/240  
**3Ø 4 WIRE (GROUNDED NEUTRAL)**

E – 120/208<sup>1</sup>  
F – 127/220  
G – 120/240<sup>1</sup>(DELTA)  
H – 220/380<sup>2</sup>  
J – 240/416  
K – 254/440  
M – 277/480<sup>1</sup>  
N – 347/600<sup>1</sup>

### 3Ø 3 WIRE

P – 208  
Q – 220  
R – 240  
S – 380<sup>2</sup>  
U – 416  
V – 480  
W – 600  
X – SPECIAL

### 16. CONTROLLER

2 – TSC 800  
7 – NONE (MANUAL)

### 17. ENCLOSURE TYPE

A – NEMA 1, ASA #61 GREY  
B – NEMA 2, ASA #61 GREY  
C – NEMA 12, ASA #61 GREY  
D – NEMA 3R SD, ASA #61 GREY  
E – NEMA 3R/4 DD, ASA #61 GREY<sup>3</sup>  
F – NEMA 3RX/4X DD  
(306 STAINLESS STEEL)<sup>3</sup>  
G – NONE (OPEN STYLE)  
H – NEMA 3RXDD (ALUMINUM),  
ASA #61 GREY<sup>4</sup>  
X – SPECIAL

### 18. UTILITY SWITCHING DEVICE

K – MOLDED CASE SWITCH 100-1200A  
M – MOLDED CASE SWITCH C/W THER-MAG  
TRIP 100-200A  
N – MOLDED CASE SWITCH C/W  
ELECTRONIC TRIP 250-1200A  
P – MOLDED CASE SWITCH C/W  
ELECTRONIC & GF TRIP 250-1200A  
Q – INSULATED CASE, FIX MOUNT SWITCH  
(800A-4000A)  
R – INSULATED CASE, FIX MOUNT SWITCH  
C/W ELECTRONIC TRIP  
(800A-4000A)  
T – INSULATED CASE, FIX MOUNT SWITCH  
C/W ELECTRONIC & GF TRIP  
(800A-4000A)  
U – INSULATED CASE, DRAW-OUT SWITCH  
(800-4000A)  
V – INSULATED CASE, DRAW-OUT SWITCH  
C/W ELECTRONIC TRIP

(800A-4000A)  
W – INSULATED CASE, DRAW-OUT SWITCH  
C/W ELECTRONIC & GF TRIP  
(800A-4000A)  
X – SPECIAL

### 19. GENERATOR SWITCHING DEVICE

K – MOLDED CASE SWITCH 100-1200A  
M – MOLDED CASE SWITCH C/W THER-MAG  
TRIP 100-200A  
N – MOLDED CASE SWITCH C/W  
ELECTRONIC TRIP 250-1200A  
P – MOLDED CASE SWITCH C/W  
ELECTRONIC & GF TRIP 250-1200A  
Q – INSULATED CASE, FIX MOUNT SWITCH  
(800A-4000A)  
R – INSULATED CASE, FIX MOUNT SWITCH  
C/W ELECTRONIC TRIP  
(800A-4000A)  
T – INSULATED CASE, FIX MOUNT SWITCH  
C/W ELECTRONIC & GF TRIP  
(800A-4000A)  
U – INSULATED CASE, DRAW-OUT SWITCH  
(800-4000A)  
V – INSULATED CASE, DRAW-OUT SWITCH  
C/W ELECTRONIC TRIP  
(800A-4000A)  
W – INSULATED CASE, DRAW-OUT SWITCH  
C/W ELECTRONIC & GF TRIP  
(800A-4000A)  
X – SPECIAL

### 20. POWER CONNECTIONS

A – STANDARD  
X – SPECIAL

### 21. ATS CONNECTION CONFIGURATION<sup>5</sup>

(SEE DRAWING 880M100)  
A – STANDARD  
B – ALTERNATE B (400-1200A)  
C – ALTERNATE C (400-1200A)  
D – ALTERNATE D (400-1200A)  
E – ALTERNATE E (800-4000A)  
F – ALTERNATE F (800-4000A)  
G – ALTERNATE G (800-4000A)  
X – SPECIAL  
NOTES:

<sup>1</sup> MULTI-VOLTAGE CAPABLE

<sup>2</sup> FOR 50HZ APPLICATION

<sup>3</sup> STANDARD ENCLOSURE RATING IS N3R  
AT 800A AND ABOVE AND N4 AT 600A  
AND BELOW.

<sup>4</sup> ONLY AVAILABLE 800A AND ABOVE.

<sup>5</sup> FOR BYPASS SWITCH APPLICATIONS  
REFER TO FACTORY.

## OPTIONAL FEATURES

(Specify separately from ATS MODEL CODE when ordering)

CODE	DESCRIPTIONS
<b>AUX-BG</b>	Generator Bypass Auxiliary Contact
<b>AUX-BU</b>	Utility Bypass Auxiliary Contact
<b>AUX-G</b>	Auxiliary Contact - Generator Side (2 included as standard, specify additional qty.)
<b>AUX-U</b>	Auxiliary Contact - Utility Side (2 included as standard, specify additional qty.)
<b>CIM</b>	Telephone Dial-up Remote Communication Module. Includes integral 14.4kbaud Modem and provides communication for up to 10 TSC 800 Controllers per system. Utilizes THS 2000 Thomson Technology Host software.
<b>EAP1601</b>	Transfer to Emergency Annunciator, Alarm Horn & Silence Pushbutton
<b>FTL</b>	Fail to Transfer Light
<b>FTT</b>	Fail to Transfer Contact
<b>GAL</b>	Generator Available Light
<b>GBL</b>	Generator Bypass Indicating Light
<b>GFL</b>	Generator Power Failure Light
<b>GPA</b>	Generator Power Available Contact
<b>GPF</b>	Generator Power Failure Contact
<b>LCK</b>	Lockable Door
<b>LDC</b>	Generator Pre/Post and Utility Pre/Post Timer Contact (Adjustable) for Load Disconnect Prior to Transfer
<b>MPC-ETN</b>	Ethernet Remote Communication Module. Provides Modbus™ TCP Protocol. Is configurable to communicate with up to 10 TSC 800 Controllers per system. Utilizes THS 2006 Thomson Technology Host software.
<b>MPC-STD</b>	Serial RS 232/422/485 Remote Communication Module. Is configurable to communicate with up to 10 TSC 800 Controllers per system. Provides Modbus™ Protocol. Utilizes THS 2006 Thomson Technology Host Software.
<b>RLDC</b>	Provisions for Remote Load Dump Contact
<b>RPRNS</b>	Provisions for Remote Permissive Retransfer to Normal Signal
<b>RPTEs</b>	Provisions for Remote Permissive Transfer to Emergency Signal
<b>RRIS</b>	Provisions for Remote Retransfer Inhibit Signal
<b>RTIS</b>	Provisions for Remote Transfer Inhibit Signal
<b>TS-DM</b>	Digital Meter (Load Side of ATS) c/w Amps, Volts, Frequency, Power Factor, kW, kVAR, Modbus™ Communications
<b>TS-H1</b>	Enclosure Strip Heater c/w Thermostat, (120VAC External Power Source Required)
<b>TS-H2</b>	Enclosure Strip Heater c/w Thermostat (Internally Powered from ATS Load)
<b>TS-O&amp;M</b>	Additional ATS O&M Manuals (Specify qty.) (Alternatively download from the web)
<b>TS ST-G</b>	Shunt Trip Generator Switch
<b>TS ST-U</b>	Shunt Trip Utility Switch
<b>UAL</b>	Utility Available Light
<b>UBL</b>	Utility Bypass Indicating Light
<b>UFL</b>	Utility Power Failure Light
<b>UPA</b>	Utility Power Available Contact
<b>UPF</b>	Utility Power Failure Contact
<b>VFD</b>	Vacuum fluorescent display for extended low temperature operation (-20° C).

\*Refer to separate literature for additional information.

™ Trademarks belong to their respective parties.

**NOTE:** Specifications subject to change without notice.  
CL061 Rev 4 08/05/01 6171Z-SK-3/08-3K-TP

THOMSON TECHNOLOGY • 9087A - 198th STREET, LANGLEY, BC CANADA V1M 3B1

TELEPHONE: (604) 888-0110 • FAX: (604) 888-3381 • E-MAIL: info@thomsontechnology.com • www.thomsontechnology.com

